

VOLVO PENTA

AQUAMATIC 130/270



The Aquamatic 130/270 is a further development of the world-renowned Volvo Penta inboard/outboard power unit consisting of a four-cylinder, four-stroke engine with an outboard drive and is by far the most modern I/O unit on the market. The engine with its drive and equipment is completely built for salt water operation under extremely hard marine running conditions and this guarantees the highest running reliability and durability.

The quiet vibration-free engine with hyper-effective intake silencer, through its high marine output and particularly low fuel consumption is specially suitable for single installation in fast boats. Its compact dimensions when installed are specially favourable in the case of twin installation in heavier fast boats. Scientific calculations and practical tests have enabled the ratio of the drive to be adapted in order to utilize engine torque to its maximum. This ensures maximum tractive effort even in the economical moderate engine speed range.

Dependable at sea

- The engine and outboard drive are fitted together through one single hole in the transom through the medium of a mounting collar in which the rear engine rubber mounting, the power transmission, exhaust and cooling channels, steering, lift and control cables are built in.

- The sturdy dimensions of the mounting collar and its large contact areas with fully protected rubber seals against the transom mean that the engine and the outboard drive form a dependable and outstandingly seaworthy unit with the boat – even in the case of extreme stresses.

- The location of the exhaust connector, at a satisfactory level above the waterline of the boat and effective protection at all joints provides full security against water forcing its way in.

Reliable running

- Particularly extensive test operations of the engine and the outboard drive in one of the most modern engine laboratories in the world and on marine test circuits guarantee unexcelled lifetime and running reliability.

- The engine is dimensioned for the utilization of full output and has stellite-flashed exhaust valves and hardened intake valves of the self-rotating type which seal against replaceable seats.

- The electrical system includes an alternator with a particularly high charging capacity and is completely protected from corrosion even down to the electric cable flat pin connectors.

Convenient for servicing

- The Aquamatic 130/270 is a modern engine, easy to use and requires no complicated maintenance.

- Service inspection free of charge after 20 hours running and also an extensive factory guarantee provide full servicing security.

- Volvo Penta has built up a well-developed service organization all over the world with workshops carrying good stocks of spares and also with specially-trained personnel at your disposal. You always have Volvo Penta service within easy reach no matter where you are.

Volvo Penta four-cylinder, four-stroke marine engine
with model 270 outboard drive

130 h.p.

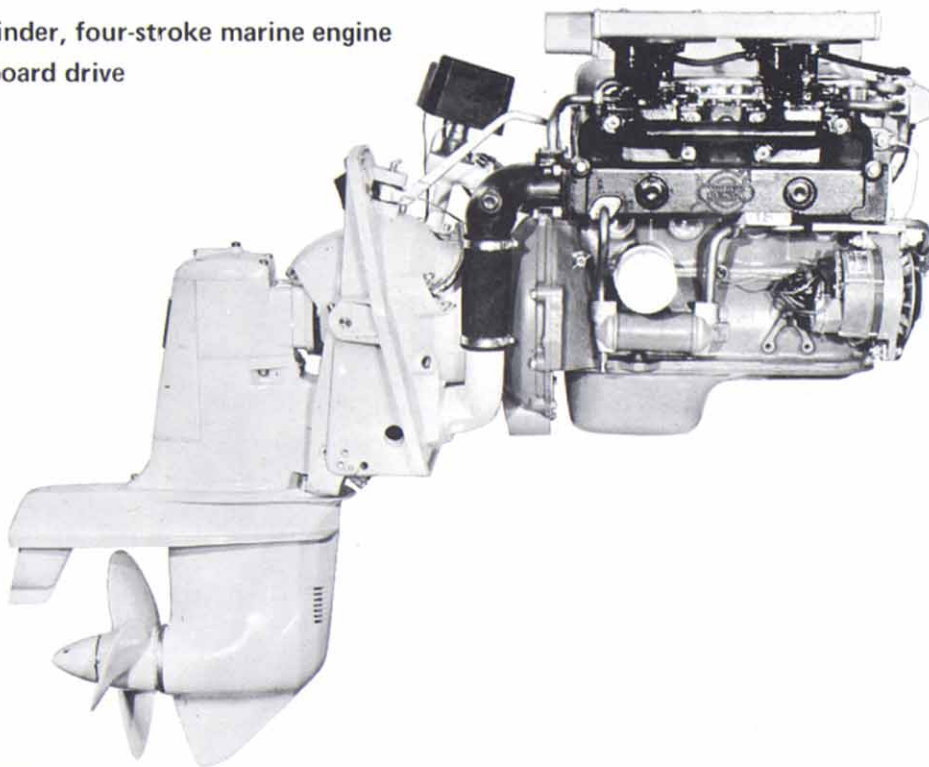

AQUAMATIC 130C/270D

1. Anti-corrosion zinc ring
2. Exhaust outlet and trimming tab
3. Oil filler
4. Casing over control units
5. Oil dipstick
6. Rubber damper for drive tip-up
7. Electro-mechanical lift
8. Steering rod with connection for steering system
9. Ignition coil
10. Twin down-draft carburetors (Solex)
11. Air intake silencer "Silent Flow" with flame arresters
12. Alternator, 12 V, 38 Amp.
13. Water cooled exhaust manifold
14. Spin-on full-flow oil filter
15. Cleanable oil cooler of tubular type
16. Exhaust pipe
17. Cooling water intake

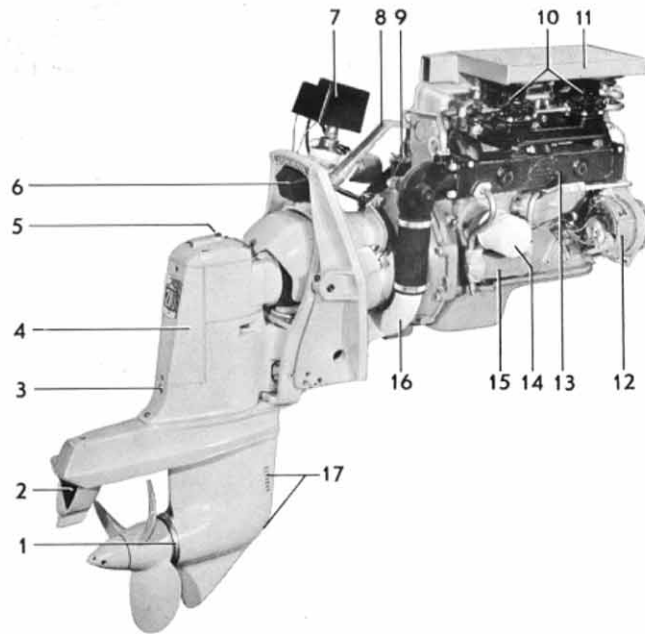

AQUAMATIC MODEL 270 OUTBOARD DRIVE

The 270 outboard drive unit is the most powerfully dimensioned outboard drive of its type on the market with an outstanding operational reliability and durability second to none. Behind its design and its corrosion-resistant and rugged construction lie the accumulated experience and considerable expertise of Volvo Penta, who were pioneers in this particular field. All gears, drive shafts and bearings on the 270 drive unit have been robustly constructed to cope with maximum loads for a long period. Thorough, long-endurance tests have confirmed without a shadow of a doubt that the 270 unit is unequalled. The propeller gear is of a new bevel type which ensures that the drive unit runs very quietly and makes continuous operation possible in either direction of propeller rotation. Changeover from left-hand to right-hand rotation is done by a simple shift change. The 270 drive unit is particularly easy to manoeuvre thanks to the smooth operation of the patented cone clutch of type "Silent Shift", as well as to the properly balanced controls which make the unit very easy to steer. The patented construction of the retaining pawl provides full security during operation "Forward" against any unexpected tipping up of the drive caused, for example,

when running in shallow waters. In emergency situations, rapid manoeuvring in reverse can also be carried out up to speeds of about 15–20 knots without the drive "floating up". The electrically operated mechanical lift unit, which is fully reliable in use, is fully enclosed and is operated within easy distance of the driving seat.

DATA

Type or operation	Four-stroke carburetor engine with overhead valves
Type designation	AQ 130C/270D
Max. output (SAE)	130 h.p.
Max. operating speed, r.p.m.	5100
Number of cylinders	4 in line
Capacity, litres (cu.in.)	1.986 (121)
Bore/stroke, mm (in.)	88.9/80(3.50/3.15)
Compression ratio ^{x)}	9.5:1
Outboard drive, type designation/ratio	270D/2.15:1
Total weight, kg(lb.), approx	230(510)

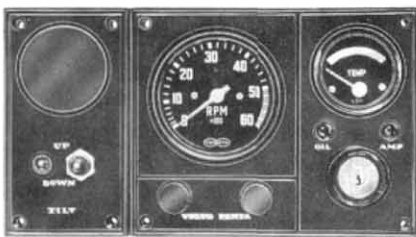

Standard equipment includes: Instrument panel of entirely new design which can be supplemented with small panels for extra instrumentation.

Also included as standard are: Electric rev. counter, temp. gauge, warning lamps for battery charging and oil pressure, switches and key switch.

All electric cables are routed together in a 7 m (23 ft.) long cable harness with plug in.

We reverse the right to carry out modification

DIMENSION DRAWING

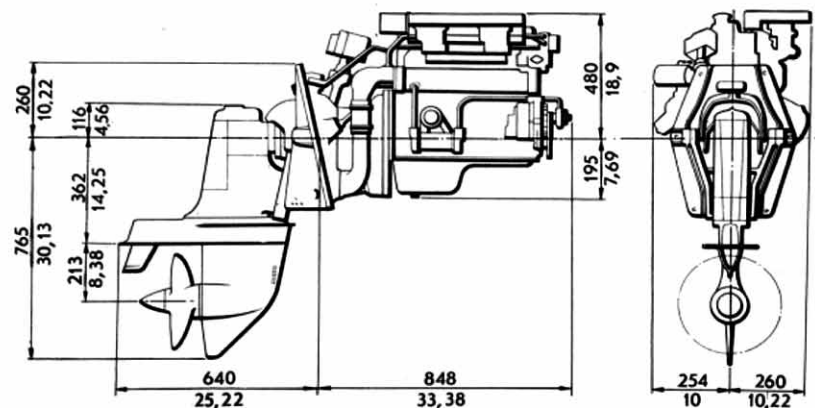

AB VOLVO PENTA

Box 392, 401 26 Göteborg 1, Sweden
 Telephone 23 54 60
 Cables: Penta
 Telex 207 55