

## AQD 40A/280



6-cylinder, 4-stroke turbo-charged marine diesel engine with swirl chambers. Outboard drive 280B

### STANDARD EQUIPMENT

**ENGINE BODY** – Cast iron cylinder block and cylinder head. Replaceable wet cylinder liners. Oil cooled pistons made of light-alloy with two compression rings and one oil scraper ring. Crankshaft journalled in seven bearings. The cylinder head is provided with replaceable valve seats and valves of high quality material. Tool kit for minor adjustment supplied with engine.

**FUEL SYSTEM** – Rotor-type injection pump with mechanical governor for accurate speed regulation (1).

Feed pump (2) with hand primer and flexible hoses with fuel pipe connection for suction and return lines.

Fine filter (3) with water separator.  
Electrical stop device.

**COOLING SYSTEM** – Thermostat-controlled fresh-water cooling with heat exchanger (4) and circulation pump. Expansion tank (5). Sea-water pump with neoprene rubber impeller (6). Cleanable sea-water filter (7).

**LUBRICATING SYSTEM** – Pressure lubricating system with full-flow lubricating oil filter of the spin-on type (8). Cleanable, tubular-type oil cooler (9). Crankcase ventilation with replaceable filter (10).

**INTAKE SYSTEM** – Intake silencer with replaceable filter (11).

**TURBOCHARGING SYSTEM** – Exhaust gas driven turbo compressor with fresh-water cooled turbine housing (12).

**EXHAUST SYSTEM** – Fresh-water cooled exhaust manifold (13). Sea-water cooled exhaust manifold elbow of cast iron with complete exhaust line for connection to the drive (14).

**ELECTRICAL SYSTEM** – Corrosionproof 12 V electrical system, with complete instrument panel. Automatic fuse with resetting button fitted on engine. Brushless alternator with built-in transistor regulator, 35 A, 420 W (15). Starter motor output 2,2 kW (3 hp) (16). Automatic alarm for oil pressure and water temperature. Concerning instrument panel, see reverse side.

**FRONT ENGINE MOUNTING** – Rubber suspended engine brackets at front of engine (17) and rubber suspension between fly-wheel housing and shield at rear.

**OUTBOARD DRIVE** – Complete with mounting collar and installation parts. All gears are of the helical cut bevel type, designed for continuous operation in either direction of rotation.

Cone clutch (patented) of Silent Shift type provides reliable operation and quiet engagement with small manoeuvring forces.

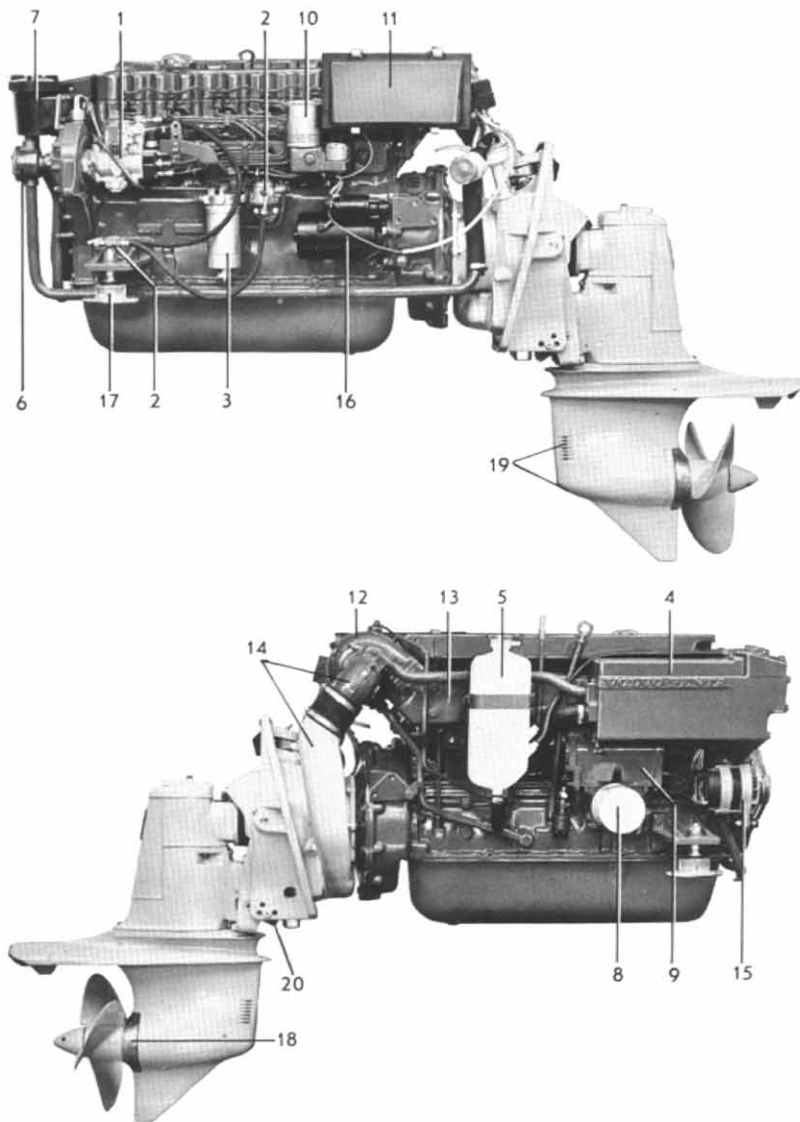

The drive can be tilted up 60°.

The shift mechanism has an easily adjustable link rod for altering the propeller direction of rotation from left-hand to right-hand.

Attachment for steering cable and steering arm with reduction mounted on the collar. Two self sacrificing zinc anodes protect the outboard drive against corrosion (18). Cooling water intake at front and bottom of drive for cooling water supply to engine (19).

Reversing pawl (20) of patented design permits the drive to kick up when striking underwater objects. Yet holding the drive in downward position when going in reverse or pulling back the throttle rapidly in forward motion.

Electro-mechanical power tilt with built in electrical system.

## EXTRA EQUIPMENT

### FUEL SYSTEM

Water-separating filter with or without flexible hoses.  
Water separator.  
Copper fuel pipe.

### LUBRICATING SYSTEM

Electrical oil scavenging pump 12 V or 24 V.

### ELECTRICAL SYSTEM

Alternator 12V 35A.  
Alternator 24V 25A.  
Charging distributor for charging 2-battery system.  
Instrument panel for extra instrument.  
Master switch.  
Cable harness extension for instrument panel.  
Safety contact for stop of engine.

### OUTBOARD DRIVE

Extension for outboard drive.

### BOAT ACCESSORIES

Electrically operated bilge pump.  
Original paint.  
Oils.

Electro-mechanical trim tabs.

### POWER TRANSMISSION

V-belt pulley for crankshaft.  
3 B-grooves Ø 165 mm.

### CONTROLS AND CONTROL SYSTEM

VP single-control lever for both speed and forward-reverse operation, top-mounted or side-mounted.  
Single or twin installation.  
Control cables.  
Steering gears.  
Steering wheel.  
Steering cables.  
Ball joint for steering cable.  
Tie-bar kit for twin installation.  
Dual station control unit.

### AQUAMATIC PROPELLERS

## DATA

Type of operation	4-stroke turbo charged diesel engine with swirl chambers
Designation	AQD40A/280B
Max output <sup>1)</sup>	130 hp (96 kW)
Max. operating speed	3600 r.p.m. (60 r.p.s.)
Number of cylinders	6 in-line
Capacity	3.59 dm <sup>3</sup> (220 in <sup>3</sup> )
Bore/stroke	92/90 mm (3.62/3.54 in)
Outboard drive, type design, and red.	280B 1.61:1
Total weight, approx.	465 kg (1025 lb)

<sup>1)</sup> Flywheel output according to DIN 6270 Leistung B.



The instrument panel is provided with a key switch, rev counter, temperature gauge, oil pressure gauge and voltmeter, warning lamp for connection of glow plugs, reostated switch for instrument panel light. Cable harness, 7 m (23 ft.) in length, with plug-in contact already fitted, for connection to engine and instrument. Control lamp and switch for drive lift and 7 m (23 ft.) electric cable harness with plug-in contact are also supplied.

## DIMENSION DRAWING

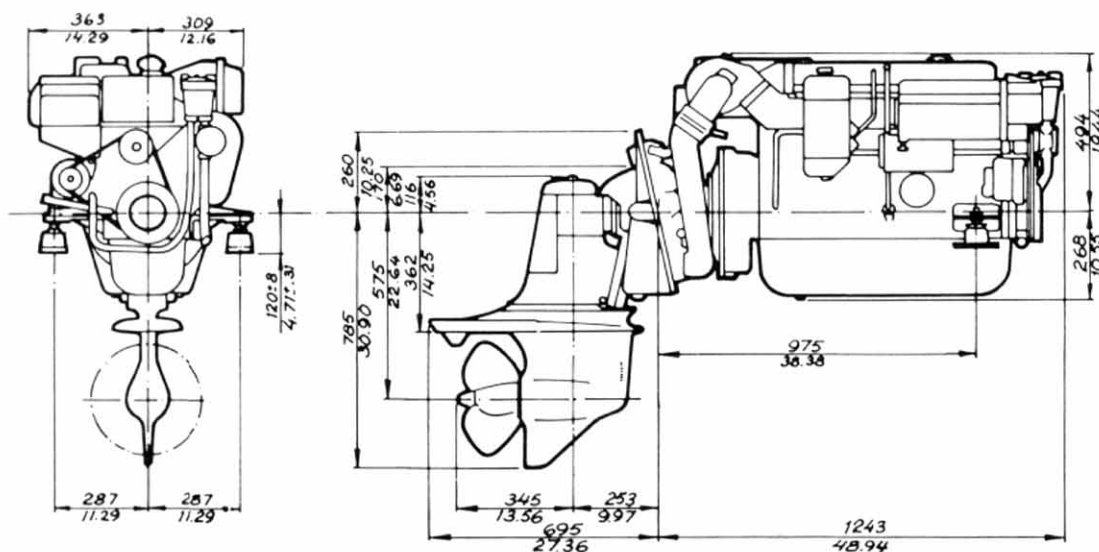

## VOLVO PENTA

S-405 08 Göteborg, Sweden

Telephone: 031/23 54 60

Cables: Penta Göteborg

Telex: 207 55 PENTA S