

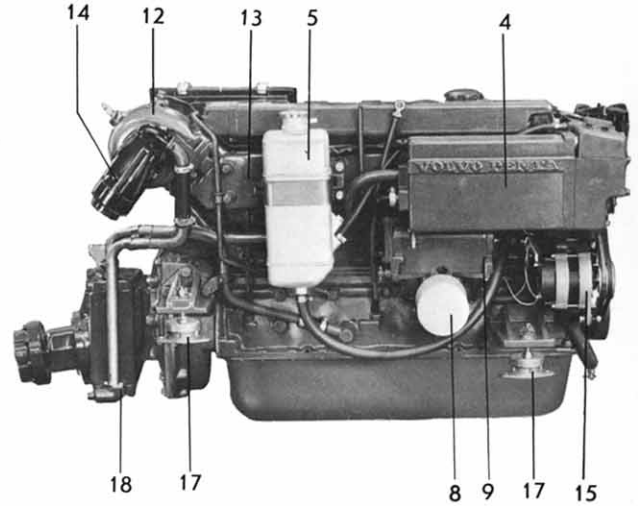

TMD 40A

6-cylinder, 4-stroke turbo-charged marine diesel engine with swirl chambers
Flywheel output 96 kW (130 hp)

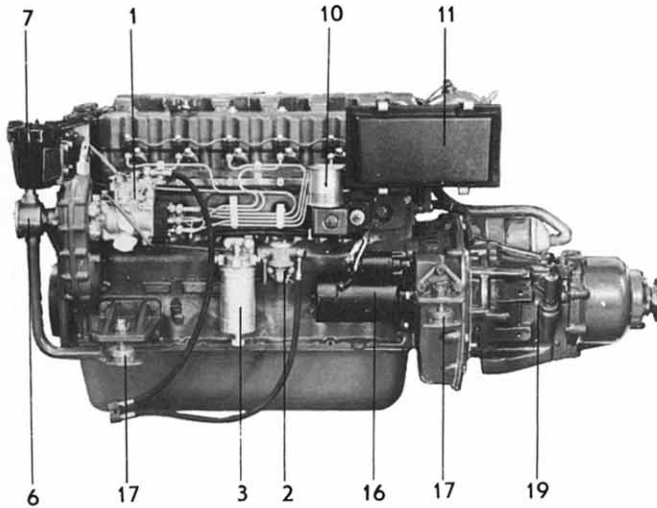

STANDARD EQUIPMENT

ENGINE BODY – Cast iron cylinder block and cylinder head. Replaceable wet cylinder liners. Oilcooled pistons made of light-alloy with two compression rings and one oil scraper ring. Crankshaft journalled in seven bearings. The cylinder head is provided with replaceable valve seats and valves of high quality material. Tool kit for minor adjustments supplied with engine.

FUEL SYSTEM – Rotor-type injection pump with mechanical governor for accurate speed regulation (1). Feed pump (2) with hand primer and flexible hoses with fuel pipe connection for suction and return lines. Fine filter (3) with water separator. Electrical stop device.

COOLING SYSTEM – Thermostat-controlled fresh-water cooling with heat exchanger (4) and circulation pump. Expansion tank (5). Raw-water pump with neoprene impeller (6). Cleanable raw-water filter (7).

LUBRICATING SYSTEM – Pressure lubricating system with full-flow lubricating oil filter of the spin-on type (8). Cleanable, tubular-type oil cooler (9). Crankcase ventilation with replaceable filter (10).

INTAKE SYSTEM – Intake silencer with replaceable filter (11).

TURBOCHARGING SYSTEM – Exhaust gas driven turbo compressor with fresh-water cooled turbine housing (12).

EXHAUST SYSTEM – Fresh-water cooled exhaust manifold (13). Raw-water cooled exhaust manifold elbow of cast iron (14) can be fitted in any angle.

ELECTRICAL SYSTEM – Corrosionproof 12 V electrical system, with complete instrument panel. Automatic fuse with resetting button fitted on engine. Brushless alternator with built-in transistor regulator, 35 A, 420 W (15). Starter motor output 2,2 kW (3 hp) (16). Automatic alarm for oil pressure and water temperature.



The instrument panel is provided with a key switch, rev counter, temperature gauge, oil pressure gauge and voltmeter, warning lamp for connection of glow plugs, re-ostated switch for instrument panel light. Cable harness, 7 m (23 ft.) in length, with plug-in contact already fitted, for connection to engine and instrument.

ENGINE MOUNTING – The engine is supplied with flexible mounting (17).

POWER TRANSMISSION – Reverse gear type MS3 with cone clutch and 8° propeller shaft angle or hydraulic reverse gear type Borg Warner. Delivered without prop. shaft flange.

Reverse gear type MS3 ratio 1.91:1, L and R-H prop. (18).
Reverse gear type BW red. ratio 1.91:1, R-H prop. (19).
Reverse gear type BW red. ratio 2.1:1, L-H prop. (19).
Reverse gear type BW red. ratio 2.9:1, L-H prop. (19).

EXTRA EQUIPMENT

FUEL SYSTEM

Water-separating filter with or without flexible hoses.
Water hoses.
Water separator.
Copper fuel pipe.

COOLING SYSTEM

Cooling water intake complete with cock and hose.
Raw water filter.
Connection parts for expansion tank.

EXHAUST SYSTEM

Hull through fitting.
Exhaust rubber hose wet.
Water-cooled silencer.
Exhaust bend 45°.
Silencer dry.

LUBRICATING SYSTEM

Electrical oil scavenging pump 12 V or 24 V.

ELECTRICAL SYSTEM

Alternator 12 V 35 A.
Alternator 24 V 25 A.
Charging distributor for charging 2-battery system.
Instrument panel for extra instrument.
Master switch.
Cable harness extension for instrument panel.
Safety contact for stop of engine.

POWER TRANSMISSION

V-belt pulley for crankshaft,
3 B-grooves Ø 165 mm.

BOAT ACCESSORIES

Electrically operated bilge pump.
Original paint.
Oils.
Electro-mechanical trim tabs.

CONTROLS AND CONTROL SYSTEM

VP single-control lever for both speed and forward-reverse operation, top-mounted or side-mounted.
Single or twin installation.
Neutral position switch – automatic safety interlock, VP controls.
Control cables.
Steering gears.
Steering wheel.
Steering cables.
Ball joint and fork kit for steering cable.
Dual station control unit.

PROPELLER EQUIPMENT

Propeller shaft flange.
Propeller shaft coupling, clamping type.
Propeller shaft.
Propeller shaft sleeves.
Propellers.

DATA

Type of operation	4-stroke turbo charged diesel engine with swirl chambers
Designation	TMD40A
Propeller shaft output pleasure boats MS3 ¹⁾ "B1"	124 hp at 3600 r.p.m. (91 kW at 60 r.p.s.)
Propeller shaft output pleasure boats BW ²⁾ "B2"	117 hp at 3600 r.p.m. (86 kW at 60 r.p.s.)
Propeller shaft output light commercial use BW ²⁾ "C"	91 hp at 3000 r.p.m. (67 kW at 50 r.p.s.)
Number of cylinders	6 in-line
Capacity	3.59 dm ³ (220 in ³)
Bore/stroke	92/90 mm (3.62/3.54 in)
Valves	overhead
Weight, engine with MS3 rev. gear, approx.	440 kg (970 lb)
Weight, engine with BW rev. gear, approx.	470 kg (1035 lb)

¹⁾ The diagram indicates the propeller shaft output for a run-in engine with mechanical reverse gear type MS3 according to DIN 6270 Leistung B. The engine flywheel output is approx. 4.8 % higher.

²⁾ The diagram indicates the propeller shaft output for a run-in engine with hydraulic reverse gear type BW according to DIN 6270 Leistung B. The engine flywheel output is approx. 11 % higher.

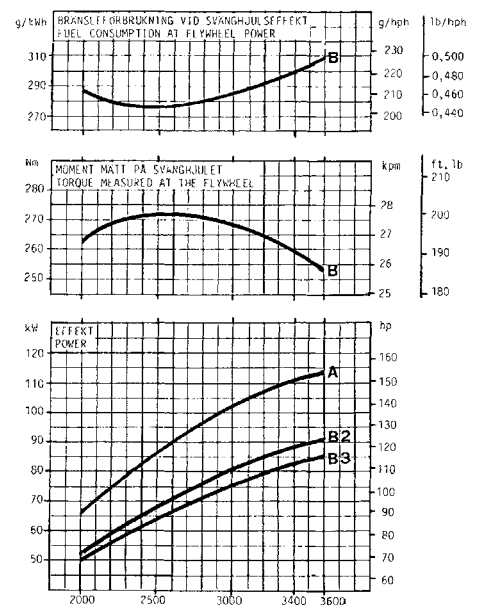

DIMENSION DRAWING

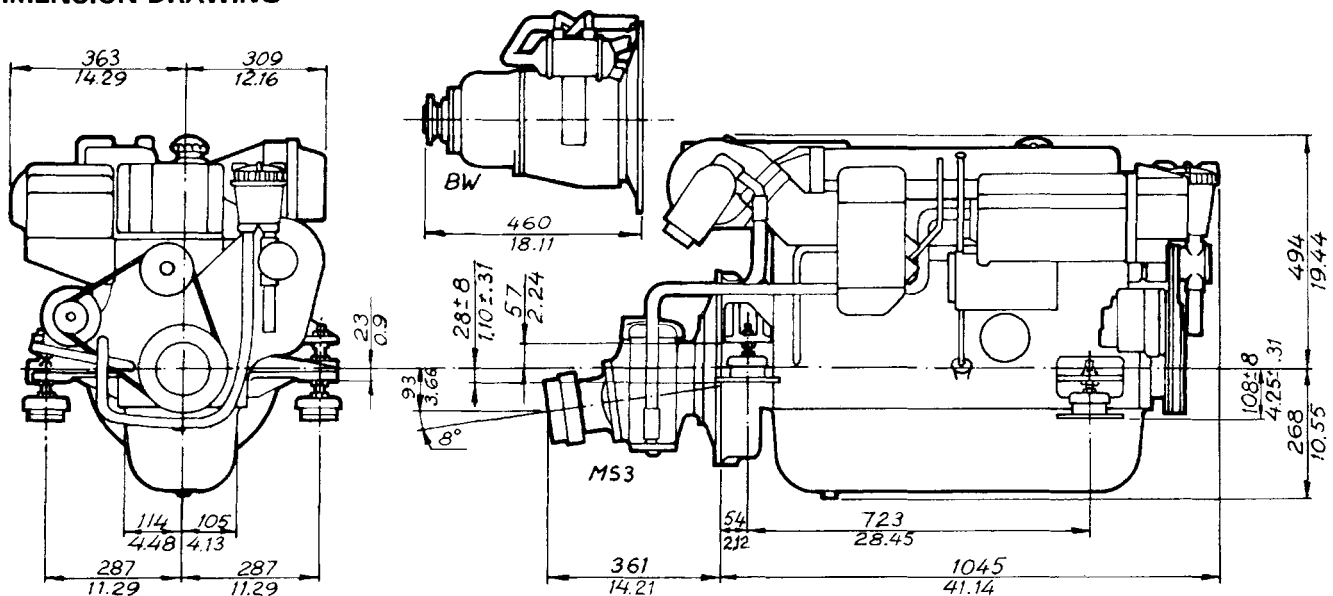

VOLVO PENTA

S-405 08 Göteborg, Sweden

Telephone: 031/23 54 60

Cables: Penta Göteborg

Telex: 207 55 PENTA S